

**ABSTRACT**

This paper presents the design configuration with the least components to realize highly efficient solar energy battery charger with PWM based voltage controlled buck converter. PWM power converter is designed to use the power MOSFET as a switching switch and be operated in a switching on and switching off model to control the power MOSFET duty cycle to achieve the buck/boost topology. PWM power converters enhance the low efficiency shortcoming of the conventionally adopted linear power converter with increasing converter switching frequency. In proposed method, a change in solar energy input is considered and control loop of converter is then designed in a way that output is constant.

**KEYWORDS:** DC-DC Buck converter, Solar battery charger, Voltage controlled converter.

**I. INTRODUCTION**

Rapid technological changes have led to power electronic products playing a crucial role in daily life. Energy storage equipment is a commonly used form of power electronic products. However, the conventionally adopted solar battery chargers produce power losses that incur power dissipation during charging. Therefore, the charging method is especially important. Various charging approaches engender various charging efficiencies and also indirectly influence the life of a battery charger. Older solar battery chargers (for RVs and boats) were primarily developed to recharge gel cell and lead acid batteries [1]. However, since the emergence of these flexible and foldable solar arrays, there has become a need to develop solar battery chargers for more portable batteries, such as Li-ion batteries. As output voltage of photovoltaic arrays varies with the sunshine, therefore the use of solar battery charger with voltage controlled buck converter is very important. As a basic topology of the DC-DC converter, the Buck converter, whose characteristics are very different from the Boost converter since it serves to convert a direct-current (DC) input voltage to a lower DC output voltage, has been widely used in engineering applications, such as computer engineering and aerospace engineering [2]. As is well known, the modeling and analysis of the Buck converter is an important step for designing this converter to satisfy the real requirements, i.e., the model's precision has a vital influence on the performance of the final design. Therefore many researchers have made an effort to establish an appropriate model and explore the corresponding analysis method. Up to now, a few good models have been proposed to describe the Buck converter, and a few good analysis methods have been explored to investigate the dynamic behavior. [2-5].

**Introduction to Buck converter**

A step-down or Buck converter produces a lower output voltage than the DC input voltage. Figure 1 constitutes a buck converter for a purely resistive load. Assuming an ideal switch, a constant instantaneous input voltage  $V_d$  and a purely resistive load, the output voltage waveform is shown in figure 2 as a function of switch position.

Figure:1

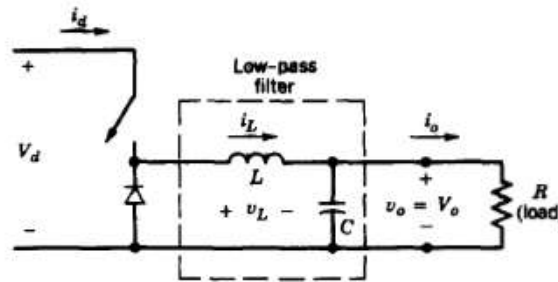

Buck converter for a resistive load

Figure:2

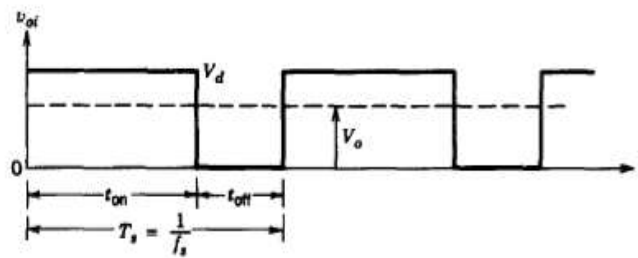

output voltage waveform

The average output voltage can be calculated in terms of switch duty ratio as

$$V_o = \frac{1}{T_s} \int_0^{T_s} v_o(t) dt = \frac{1}{T_s} \int_0^{t_{on}} v_o(t) dt + \frac{1}{T_s} \int_{t_{on}}^{T_s} v_o(t) dt = \frac{t_{on}}{T_s} V_d = D V_d$$

By varying the duty ratio ( $t_{on}/T_s$ ) of the switch, output voltage  $V_o$  can be controlled.

**Analysis of open loop buck converter**

Figure 3 shows the feedback system for a buck converter. First, transfer functions  $T_p(s)$  for the Pulse Width Modulation (PWM) stage and the power stage are identified. These two blocks are commonly grouped as the modulator.  $T_c(s)$  is the compensation network transfer function.

Figure:3

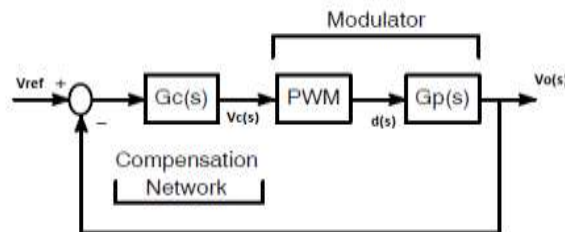

Feedback Control Loop for Buck Converter

The transfer function for the output,  $V_{out}$  with respect to duty ratio,  $D$  is

$$T_p(s) = \frac{V_o(s)}{d(s)} = V_d \frac{\omega_o^2}{\omega_z} * \frac{S + \omega_z}{S^2 + 2\xi\omega_o S + \omega_o^2}$$

Where

$$\xi = \frac{1}{2\omega_o} \left( \frac{rc+rl}{RC + \frac{L}{s}} \right), \quad \omega_o = \frac{1}{\sqrt{LC}}, \quad \omega_z = \frac{1}{rc.C}$$

For PWM the PWM stage transfer function is

$$\frac{d(s)}{V_c(s)} = \frac{1}{V_m}$$

So the open loop transfer function for output  $V_o$  with respect to the compensation network control voltage  $V_c$  is

$$\frac{V_o(s)}{V_c(s)} = \frac{V_d}{V_m} * \frac{1+S.C.rc}{LC.S^2 + \left[\frac{L}{R} + C(rc+rl)\right]S + 1}$$

**Solar Power and I-V Characteristics**

Incident sunlight can be converted into electricity by photovoltaic conversion using a solar panel. A solar panel consists of individual cells that are large-area semiconductor diodes, constructed so that light can penetrate into the region of the p-n junction. The junction formed between the n-type silicon wafer and the p-type surface layer governs the diode characteristics as well as the photovoltaic effect. Light is absorbed in the silicon, generating both excess holes and electrons. These excess charges can flow through an external circuit to produce power. Figure 5 illustrates the I-V curve and power output of a solar panel.

Figure:4

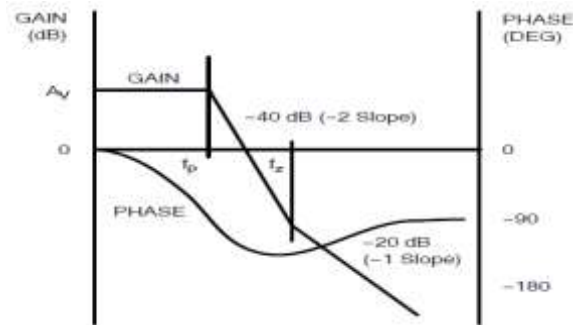

Frequency Response of Buck Modulator

Figure:5

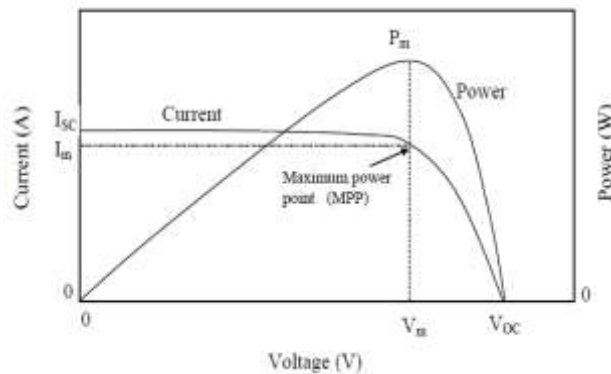

IV characteristics of solar panel

**II. DESIGN OF OPEN LOOP BUCK CONVERTER**

When solar panel is use as input energy source to buck converter, while designing the converter the variations in solar arrays should be considered which can affect on output voltage of solar panel. So by considering these variations the design of buck converter is as follows [2]:

Figure 6 shows the waveforms of the current at the CCM/DCM boundary for  $V_d=V_{dmin}$  and  $V_d=V_{dmax}$ . The maximum load current is

$$I_{omax} = \frac{P_{omax}}{V_o}$$

The minimum value of load resistance is

$$R_{min} = \frac{V_o}{I_{omax}}$$

Figure:6

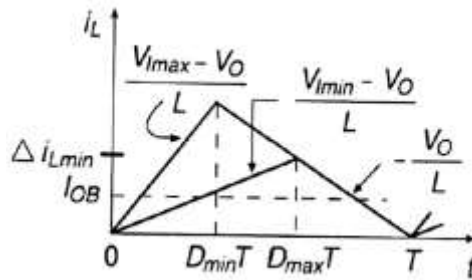

Waveform of the inductor current at the CCM/DCM for  $V_d=V_{dmin}$  and  $V_d=V_{dmax}$

The DC voltage transfer function for  $V_d=V_{dmin}$  and  $V_d=V_{dmax}$  are

$$M_{v Dc} = \frac{V_o}{V_d} = \frac{D}{D + D1}$$

If converter efficiency is  $\eta$  then maximum duty cycle at DCM at full load  $R_{min}$  occurs at  $V_{dmin}$  which is given by

$$DB_{max} = \frac{M_{v max}}{\eta}$$

The maximum value of inductor required for DCM operation is

$$L_{max} = \frac{R_{min}(1 - DB_{max})}{2fs}$$

$DB_{max}$  is the maximum duty cycle which is given by

$$D_{max} = \sqrt{\frac{2fs \cdot L \cdot (M_{v max})^2}{\eta \cdot R_{min}(1 - M_{v max})}}$$

The minimum value of duty cycle at  $M_{v max}$  is

$$D1_{min} = D_{max} \left( \frac{1}{M_{v max}} - 1 \right)$$

Where

$$D_{max} + D1_{min} < 1$$

The voltage stress of the of the switch and the diode in DCM for steady state operation is,

$$V_{smax} = V_{DMmax} = V_{dmax}$$

The current stress of the switch and the diode in DCM for steady state operation is

$$I_{smax} = I_{DMmax} = \Delta iL_{max} = \frac{D_{min}(V_{dmax} - V_o)}{f_s \cdot L}$$

If the % Vr be the ripple voltage in output, then the ripple in output voltage is

$$V_r = \%Voltage\ ripple \times V_o$$

The minimum effective series resistance of capacitor is

$$r_{c\ max} = \frac{V_r}{\Delta iL_{max}}$$

The minimum value of filter capacitor is

$$C_{min} = \frac{1}{2 \cdot r_c \cdot f_s}$$

For solar battery charger with range of input voltage  $24 < V_d < 30$ , output voltage  $V_o = 14\ V$ , 3% output voltage ripple and switching frequency  $f_s = 100\ kHz$ , the design parameters are as shown in Table 1

Table:1

Table 1. Design parameters

Vd min	24	D max	56.51%
Vd nor	27	D nor	46.73%
Vd max	30	D min	39.96%
Ripple Voltage	0.42 V		
Effective series resistance	0.05773 Ω		
Filter inductor (L)	8.8μH		
Filter Capacitor(C)	86.61μF		

### III. VOLTAGE CONTROLLED BUCK CONVERTER

Figure 7 shows linearized feedback control system for open loop buck converter. [6]. The output voltage of Buck converter is regulated to be within a specified ripple voltage in respect to change in output load and the input voltage. This is achieved by using a negative feedback control system as shown in figure 7, where output voltage  $V_o$  is compared with its reference value  $V_{oref}$ . The comparator produces the control voltage  $V_c$ , which is used to adjust the duty cycle ratio  $d$  of the MOSFET in converter. In the direct duty ratio pulse-width modulator, the control voltage  $V_c$ , which is the output of comparator (error amplifier), is compare with repetitive waveform, which establishes the switching frequency  $f_s$  as shown in figure 8 to generate gate pulses of MOSFET.

Figure:7

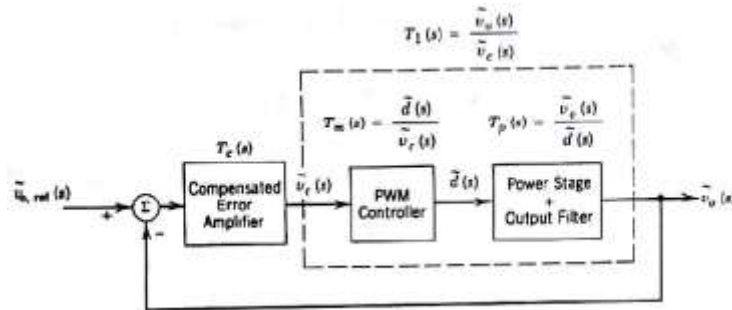

Linearized feedback control system for open loop Buck converter

Figure:8

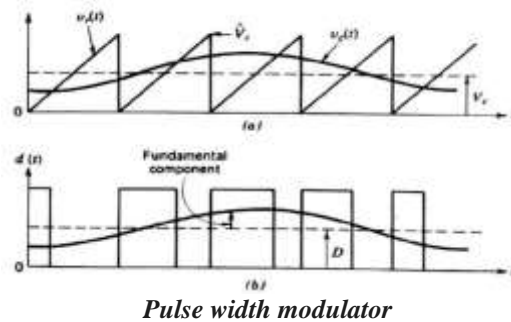

#### IV. PROPORTIONAL-INTEGRAL CONTROLLER

This is a control mode that results from a combination of proportional and integral mode. The analytic expression for this process is

$$p = K_p \cdot ep + K_p \cdot K_i \int_0^t ep \cdot dt + Pi(0)$$

The main advantages of this composite control mode are that one-to-one correspondence of the proportional mode is available and the integral mode eliminates the inherent offset. The integral function provides the required new controller output, thereby allowing the error to be zero after a load change. The integral feature effectively provides a reset of the zero error output after load change occurs. When the error is zero the controller output is fixed at the value that the integral term had when error went to zero. If the error is not zero, the proportional term contributes a correction and the integral term begins to increase or decrease the accumulated value depending upon the sign of error.

In the solar battery charger the PI controller is used as a controller, where the values of proportional and integral gain  $K_p$  and  $K_i$  are fixed with Ziegler Nichols method of tuning of the analog controller.

#### V. SIMULATION RESULTS

In order to analyze the output of the buck converter, a designed converter is modelled in MATLAB Simulink. The simulation results for voltage controlled converter shows the variation of the output voltage across battery with variation in input voltage with predetermined percentage ripple. The stability of the converter is analysed by plotting step response and bode plot for the converter transfer function.

Figure:9

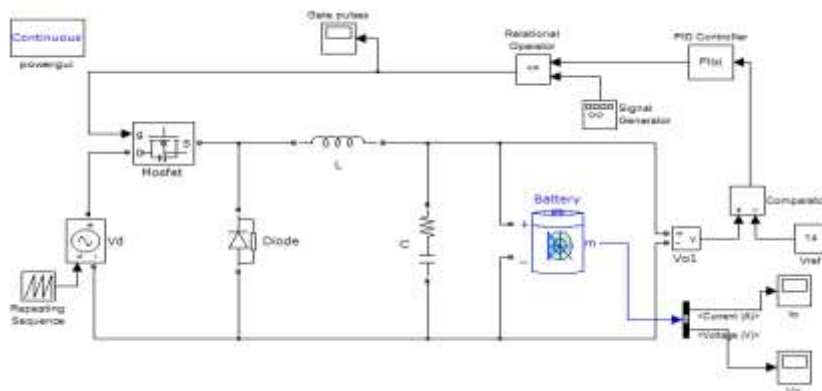

MATLAB Simulink model of voltage controlled Buck converter

Figure:9

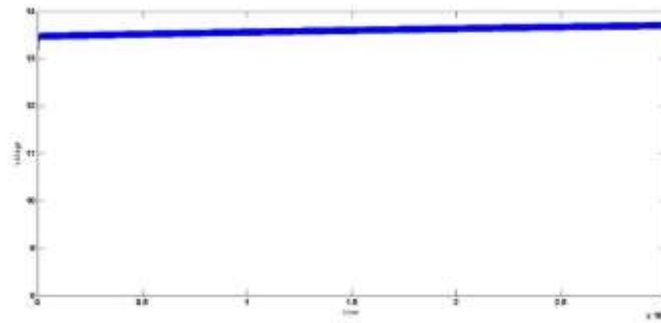

*Output voltage (battery voltage) for open loop buck converter*

Figure:10

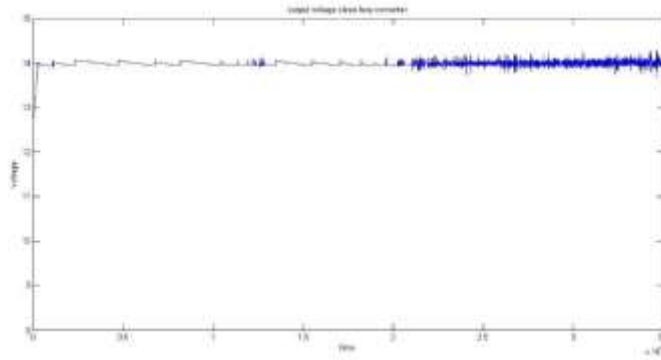

*Output voltage (battery voltage) for close loop buck converter*

Figure:11



*Gate pulses of MOSFET for close loop converter*

Figure:12

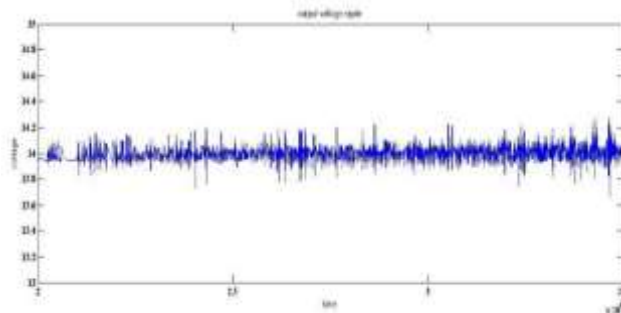

*Output voltage ripple for close loop converter*

Figure:13

*Frequency response (Bode plot) for close loop converter*

Figure:14

*Step response for close loop converter*

## VI. CONCLUSION

In this paper, a relatively comprehensive study was done about the design of solar battery charger with voltage controlled buck converter using linearized negative feedback control system with PWM technique. In this design, variations in solar input energy were considered. With designed parameters of the converter and controller it was found that the output voltage of converter was remains constant with variation in solar input energy within considered range.

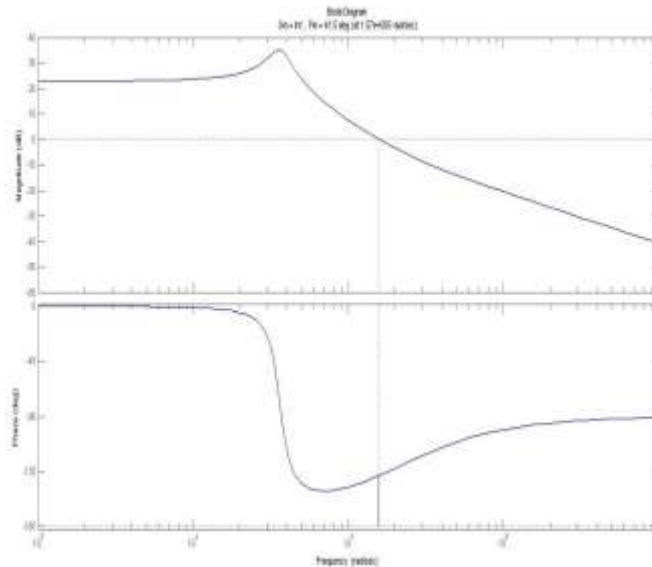
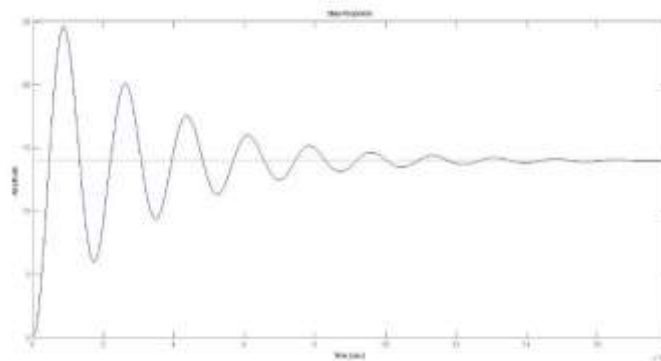
## VII. REFERENCES

- [1] E. Koutroulis and K. Kalaitzakis, "Novel battery charging regulation system for photovoltaic applications," Proc. Inst. Elect. Eng., vol. 151, no. 2, pp. 191–197, Mar. 2004.
- [2] Marian K. Kazimierczuk "Pulse width Modulated DC-DC Power converters" Wiley publication 2008
- [3] Czarkowski D and Kazimierczuk M K 1993 IEEE Trans. Aerosp. Electron. Syst. 29 1059
- [4] A Novel High-Efficiency Battery Charger with a Buck Zero Voltage-Switching Resonant Converter, Ying-Chun Chuang and Yu Lung Ke, Senior Member, IEEE.





- [5] E. Koutroulis and K. Kalaitzakis, "Novel battery charging regulation system for photovoltaic applications," *Proc. Inst. Elect. Eng.*, vol. 151, no. 2, pp. 191–197, Mar. 2004
- [6] Ned Mohan, Tore Undeland and William Robbins "Power Electronics Converter application and Design"  
Wiley publications 2003

#### CITE AN ARTICLE

Sansare, V. A., Kasar, N. N., Mane3, J. J., & Gaikwad, A. (2017). DEVELOPMENT OF SOLAR PV BATTERY CHARGER WITH BUCK CONVERTER. *INTERNATIONAL JOURNAL OF ENGINEERING SCIENCES & RESEARCH TECHNOLOGY*, 6(6), 182-190. doi:10.5281/zenodo.808962